

The 22 system is a departure from conventional cover plate systems, and requires precision and skilled craftsmanship during installation. If you have never installed a 22, bocci recommends a practice installation.

1

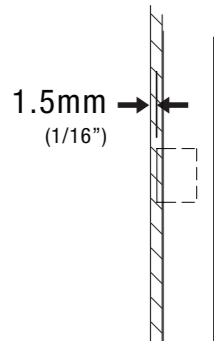

For optimum strength, make sure the back of the mounting plate meets the junction box (the surface of the junction box must be approx. 1.5mm or 1/16" back from face of drywall). If there is no direct contact between the back of the mounting plate and the junction box, the system will perform, but not at its peak strength.

2

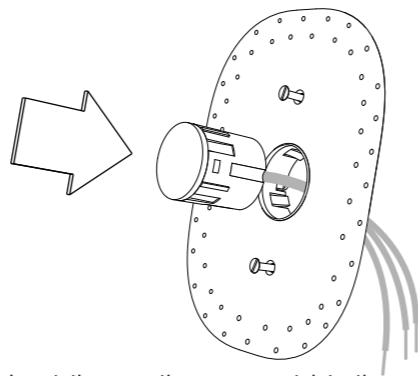

Insert the operative component into the opening in the mounting plate. Ensure that all four locking tabs engage. The operative component comes with a two layer protective cap. This will be used in further steps to mask the component during the "mudding in" process. Leave the cap in place as you insert the component into the mounting plate.

3

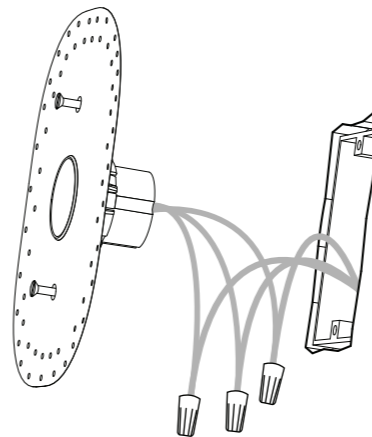

Connect the wires from the operative component to the corresponding wires in the junction box using small marettes.

4

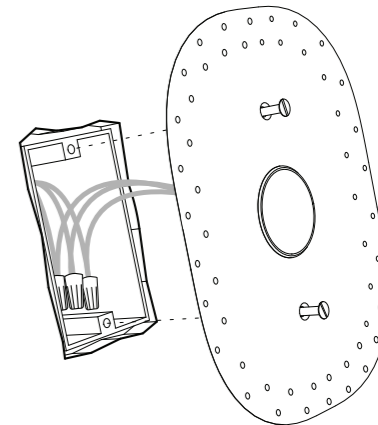

Fasten the mounting plate to the junction box using the screws provided.

5

Tape the mounting plate edges with fiber mesh drywall tape.

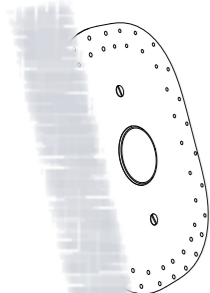

6

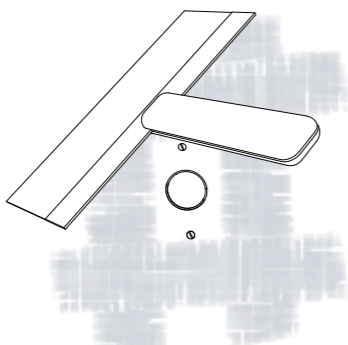

Use a drywall filler compound to "mud over" the entire assembly - feather from the center of the mounting plate outwards using a large drywall trowel.

7

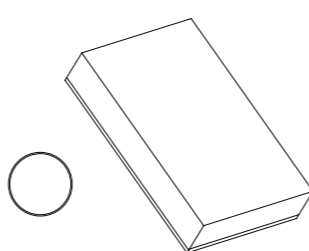

Using a foam sanding block, sand entire area until the rim and the protective cap of the operative component are exposed. For long term performance, it is essential that mud is sanded right down to the plastic rim.

8



Partially peel back paper face of protective cap ensuring silicone layer remains snugly in place around operative component. This will allow you to locate the component after painting.

9

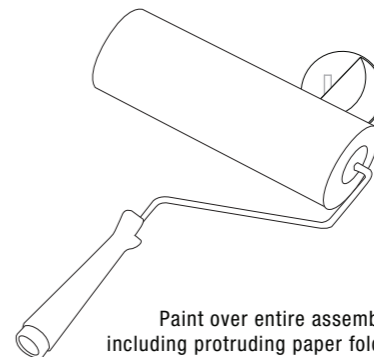

Paint over entire assembly including protruding paper fold.

10

Once dry, peel entire paper face. A tab in the silicone layer of the protective cap will be exposed under the paper - this will allow you to remove the silicone layer and expose the operative component.

